

# Preparation of Ultrafine Alumina Powders by Plasma Evaporation

D. A. EVEREST, I. G. SAYCE, B. SELTON

*Division of Inorganic and Metallic Structure, National Physical Laboratory, Teddington, Middlesex*

It has been shown that the centrifugal liquid-wall furnace is a convenient and economically attractive tool for the vaporisation of alumina. A reducing environment, conveniently supplied by using composite cores of alumina and particulate carbon, can greatly increase the evaporation rate and, on reoxidation of the vapour produced, an ultrafine oxide of high and controllable surface area is obtained.

The product is comparable with fumed aluminas made commercially by the oxidation of aluminium halides in the oxyhydrogen flame. Potential applications include flow control of liquids and powders, reinforcement of elastomers and adhesives, ceramic fabrication and heterogeneous catalysis.

## 1. Introduction

The production of fine oxide powders by condensation from the vapour phase is a well-established technique, but the oxide vapour is generally obtained by chemical reaction. Thus, fumed silica and alumina are conventionally manufactured by oxidation of the chloride vapour, typically in an oxyhydrogen flame, although a plasma reactor may also be used [1]. An alternative route to these materials is to vaporise the oxide itself, but the evaporation of such refractory and involatile materials at commercially attractive rates and efficiencies has, until recently, proved difficult to achieve. Indeed, this difficulty has been one of the major barriers hindering the more extensive use of high temperature plasma techniques in chemical and materials synthesis.

Feeding a powder directly into a thermal plasma commonly results in fusion, but relatively little evaporation [2], and it appears doubtful that efficient evaporation can be achieved by the simple introduction of powdered material into a thermal plasma. In order to achieve efficient vaporisation, it is necessary to increase the retention time of the material in the plasma, and to improve the heat transfer in some way.

One solution to the problem is found in the high-intensity arc method, developed by Sheer and co-workers [3]. The material to be vaporised, usually compacted with carbon to obtain suffi-

cient electrical conductivity, is made the anode in a high current DC arc. When the arc functions in the "high-intensity" mode, rapid evaporation of the anode is achieved, and high evaporation efficiencies can be obtained, e.g. figures of 9 to 18 kW h/kg have been reported for the evaporation of silica [4]. However, the technique suffers from the disadvantage of having to fabricate and feed the electrodes. Further, the temperature of the vaporised species generally must be raised well above the boiling point in order to maintain the arc, thus leading to an increased power consumption and loss of evaporation efficiency.

The use of the centrifugal liquid-wall furnace represents an alternative solution to the problem. Such devices, heated by plasma means, have been used for the containment of fused refractories [5-7] and preliminary vaporisation experiments have already been reported [7]. Further development has shown that evaporation of alumina may be rapid and economical, and condensation of the vapour under controlled conditions yields ultrafine oxide powders with a range of properties and with a wide variety of potential applications.

## 2. Species Vaporised

Under neutral conditions, the vapour species in equilibrium with molten alumina in the temperature range 2100 to 2600°K comprise mainly oxygen and aluminium atoms [8]. There exist

also smaller quantities of the gaseous suboxides  $\text{AlO}$  and  $\text{Al}_2\text{O}$ , together with traces of  $\text{Al}_2\text{O}_2$ . In a reducing environment, the total vapour pressure over molten alumina is considerably increased, the major aluminium-containing vapour species being atomic aluminium and  $\text{Al}_2\text{O}$ , with the latter predominating above  $1800^\circ\text{K}$  [9, 10].

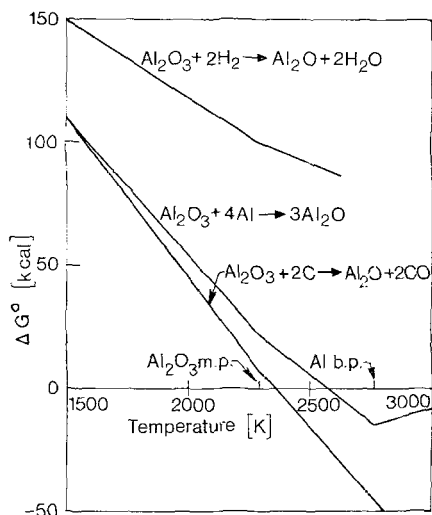
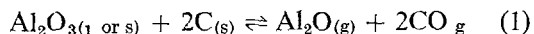

Figure 1 Plots of free energy versus temperature for the reduction of alumina to  $\text{Al}_2\text{O}$  by hydrogen, aluminium and carbon.

In the present study, alumina was evaporated under neutral conditions, and in the presence of hydrogen, metallic aluminium, or carbon as reducing agents. The free energy-temperature plots for the reduction of alumina to  $\text{Al}_2\text{O}$  by these reagents are shown in fig. 1. In order to minimise power consumption, it is necessary to effect evaporation at the minimum practical temperature, and it is clear from these plots that in this regard, hydrogen will be a poor reducing agent, aluminium metal considerably better, and carbon better still. In fact, thermochemical evidence [11] indicates that the total pressure of gaseous species produced in the reaction:



reaches one atmosphere at about  $2300^\circ\text{K}$ . Furthermore, the presence of other aluminium vapour species, and the fact that the alumina surface is constantly purged with fresh gas, mean that extensive evaporation should occur well below this temperature.

The carbothermic reduction of alumina has, of course, been much studied as a possible route to the metal [10], the vaporisation of the aluminium suboxide species being one of the major difficulties in this process. The condensed species believed to participate in the reaction include, in addition to alumina and carbon, the oxycarbides  $\text{Al}_2\text{OC}$  and  $\text{Al}_4\text{O}_4\text{C}$ , and aluminium carbide,  $\text{Al}_3\text{C}_4$ . In the presence of nitrogen,  $\text{AlN}$  and  $\text{AlCN}$  may also be present.

It thus appears likely that on heating a solid mixture of alumina and carbon (in the molar ratio 1:2) in a nitrogen atmosphere, reaction will occur within the solid to form some  $\text{Al}_2\text{OC}$ ,  $\text{Al}_4\text{O}_4\text{C}$  and possibly some nitrogen-containing species. Under these circumstances, fusion begins at 2100 to  $2200^\circ\text{K}$ , and at this point the rate of reaction increases markedly and evaporation begins to occur. Formation of a uniform liquid phase takes place at 2200 to  $2300^\circ\text{K}$  and at higher temperatures rapid evaporation will occur,  $\text{Al}_2\text{O}$  and  $\text{Al}$  being the predominant vapour species.

### 3. Apparatus and Materials

The apparatus is shown schematically in fig. 2. Both the plasma jet and the furnace have been described previously [7, 12], but modifications enabled the continuous use of higher enthalpy plasmas. Most important of these changes was the use of a directly water-cooled tungsten cathode in the plasma jet, and the use of a furnace barrel in cadmium-plated mild steel with a deep helical fin cut in the outer surface. This greatly improved heat transfer to the cooling water, and prevented steam formation on the hot metal surface. Finally, omission of the pellet injection nozzle enabled greater efficiencies to be achieved. The plasma power was provided by a Hirst Electric Industries Ltd Plasma Power Source 320/185.

Each experiment began with a new alumina core and no attempt was made to replenish the furnace during the course of an experiment. As described below, a reducing environment was used to increase the evaporation rate, and the vapour leaving the furnace was therefore treated with an arrangement of air jets in order to re-oxidise the vapour species and quench the product. The gas stream, laden with alumina powder, was cooled by passing through a water-cooled tube and led into an electrostatic precipitator where the greater part was collected. Further powder could also be collected beyond the pre-

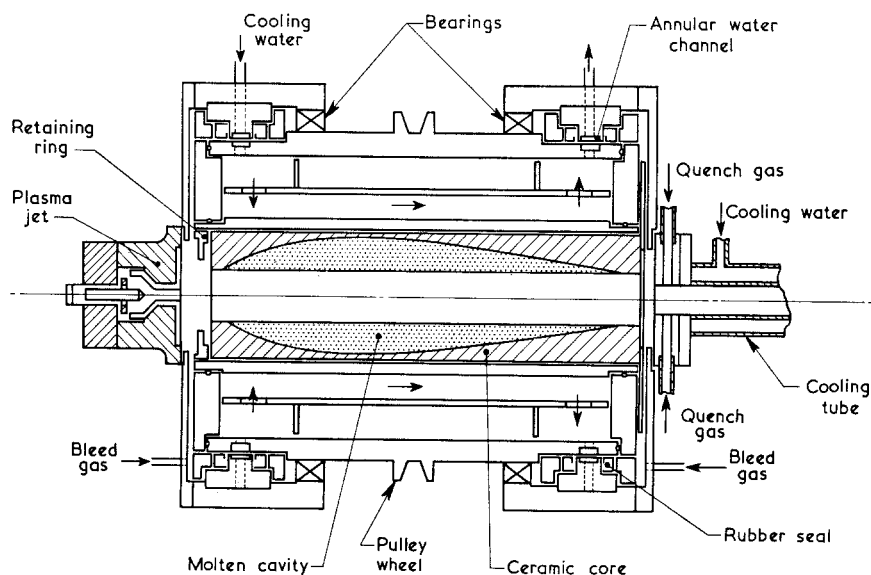

Figure 2 Centrifugal liquid-wall furnace.

cipitator by the use of bag filters. The effluent was then fed via a water scrubber to waste.

The furnace cores were made using a moulding technique employing a commercial castable alumina (W. and C. Spicers Ltd) or a ramming composition (Cawood Wharton Ltd). The former contains calcium aluminate as binder and yields a product containing up to 5% calcium oxide; it was used only in the initial stages of the work. The latter composition employs aluminium polyoxochloride as binder and yields substantially pure alumina on firing.

Any aluminium ("fine powder" supplied by Hopkin and Williams), or carbon (petroleum coke flour, British Acheson Electrodes) employed as reducing agent was incorporated during the casting procedure, and firing of the ceramic was carried out in an inert atmosphere. The gases employed (supplied by British Oxygen Co, Ltd) were "oxygen-free" grade nitrogen and hydrogen and high purity argon. Gas flows are quoted below in l/min corrected to STP.

#### 4. Experimental Results and Discussion

The present work was concerned mainly with developing an efficient method for evaporating alumina. The control which may be achieved over the properties of the oxide product is to be the subject of a later paper. The factors studied include the choice of reducing agent and plasma gas, and the variation of evaporation rate with time and with input power.

##### 4.1. Effect of Reducing Agent

The results of a series of experiments demonstrating the effect of no reducing agent, and of hydrogen, aluminium, and carbon, are shown in table I. These experiments were each of 12 min duration, and employed a plasma input power of 25 kW. Using nitrogen as plasma gas, a pure alumina core was found to evaporate at an average rate of 6.7 g/min. A small percentage addition of hydrogen to the plasma gas did not increase the evaporation rate, but caused a slight decrease, while the use of a plasma containing a high proportion of hydrogen resulted in a very low evaporation rate of alumina. It is thus clear that hydrogen is a poor reducing agent, and the decrease in evaporation rate may result in part from the fact that these hydrogen-containing plasmas have, for the enthalpy (70 to 80 kcal/mole), much lower temperatures than do plasmas of argon or nitrogen [13]. It was, however, observed that the plasma jet operated with particular stability using a gas mixture containing nitrogen (71 l/min), and hydrogen (10 l/min), and this mixture was used extensively during the remainder of the work.

With a core containing a 4:1 mole ratio of aluminium metal to alumina, the evaporation rate of alumina was somewhat higher than that of the pure oxide. The comparatively low evaporation rate achieved in this case probably results from the fact that much molten aluminium was centrifuged from the reaction zone out

**TABLE I** Effect of reducing agent on evaporation rate of alumina; runs of 12 min duration at 25 kW input power.

Plasma gas		Reducing agent	Total core loss (g)	Total loss as Al <sub>2</sub> O <sub>3</sub> (g)	Average Al <sub>2</sub> O <sub>3</sub> evaporation rate (g/min)
N <sub>2</sub> (l/min)	H <sub>2</sub> (l/min)				
80	—	None	80	80	6.7
71	10	Plasma H <sub>2</sub>	50	50	4.2
10	70	Plasma H <sub>2</sub>	31	31	2.6
71	10	4 moles Al	114	55	4.6
71	10	2 moles C	340	275	23.0
80	—	2 moles C	278	225	18.8

through the porous alumina furnace lining, leaving the evaporating surface depleted of reducing agent.

As shown by the last two experiments described in table I, high evaporation rates are obtained when carbon is employed as reducing agent. The presence of a small proportion of hydrogen in the plasma appears to aid volatilisation in these experiments, suggesting that carbon-hydrogen species may be involved in the evaporation process.

Carbon having been selected as the most suitable reducing agent, a series of experiments was carried out to determine the optimum ratio of carbon to alumina in the furnace core (table II). With nitrogen plasmas operating at 30 kW input power the average evaporation rate is higher for a core containing a 2:1 mole ratio of carbon to alumina than for either 1:1 or 3:1 ratios. The same 2:1 ratio was the optimum also when the standard (71:10) nitrogen-hydrogen mixture was employed as plasma gas at 25 kW input power. This stoichiometry corresponds to that required by equation 1 above, supporting the conclusion that Al<sub>2</sub>O is the major aluminium-containing vapour species in this system. This core composition was used throughout the remainder of the study.

#### 4.2. Change in Evaporation Rate with Time

At the present time a batchwise distillation process is employed, each experiment beginning with a new core and a cold furnace. It is thus inevitable that the distillation rate will change with time, and this factor was investigated experimentally. The results, plotted in fig. 3, show that the evaporation rate increases over the first few minutes of the run, becoming approximately constant between 8 and 12 min after the start of the experiment. The maximum gradient of this curve corresponds to a peak evaporation rate of about 1.9 kg/h at 25 kW, which in turn corresponds to a power requirement of about 13 kWh/kg. This may be compared with a theoretical figure of about 4.4 kWh/kg calculated for the carbothermic reduction of alumina to Al<sub>2</sub>O using JANAF thermochemical data [11].

#### 4.3. Effect of Input Power

In fig. 4 are shown values for the dependence of distillation rate upon input power in experiments of 8 min duration, using the standard (71:10) nitrogen-hydrogen mixture as plasma gas; in the range investigated the relationship is approximately linear. The line does not pass through the origin as there is a minimum power (about 9 kW) at which distillation will take place. Extra-

**TABLE II** Experiments to determine optimum carbon content of core.

Duration (min)	Power (kW)	Plasma gas		Carbon content moles/mole Al <sub>2</sub> O <sub>3</sub>	Total Al <sub>2</sub> O <sub>3</sub> evaporated (g)	Average Al <sub>2</sub> O <sub>3</sub> evaporation rate (g/min)
		N <sub>2</sub> (l/min)	H <sub>2</sub> (l/min)			
14	30	84	—	1.0	228	16.3
12	30	84	—	2.0	332	27.6
12	30	84	—	3.0	325	27.1
8	25	71	10	1.5	134	16.8
8	25	71	10	2.0	197	24.6
8	25	71	10	2.5	170	21.3

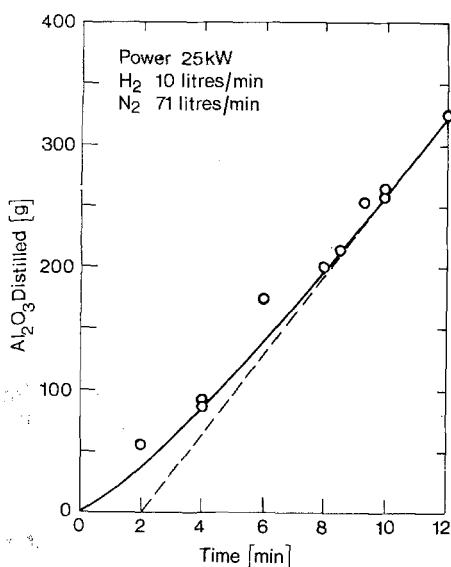

Figure 3 Plot of weight of alumina distilled versus time.

polation to higher input powers suggests that the average distillation rate, using the present apparatus, would be about 140 g/min at 100 kW input power (compared to 25 g/min at 25 kW); the corresponding power consumptions are 11.9 and 16.7 kWh/kg respectively. Peak distillation rates and efficiencies would, of course, be higher than these average values. These results indicate that the process is more efficient at higher

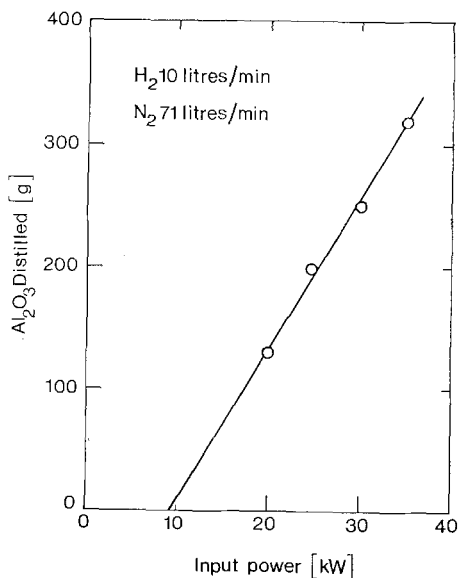

Figure 4 Effects of plasma input power on alumina distillation rate for experiments of 8 min duration.

plasma input powers, and scale-up of the apparatus will give further improvement in efficiency.

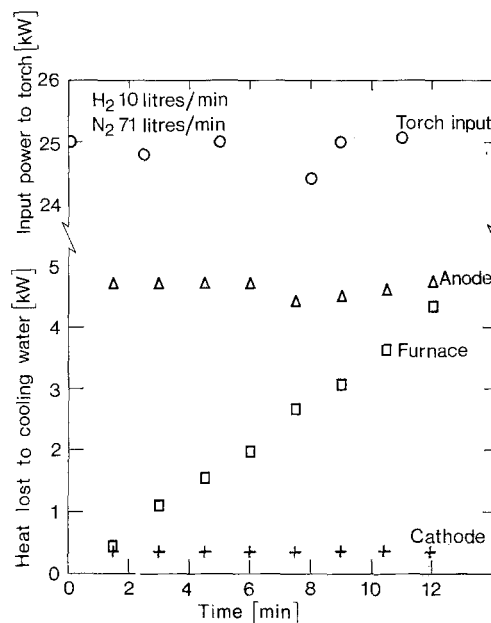

Figure 5 Heat losses to cooling water in various parts of apparatus during a typical experiment.

The heat losses to the furnace cooling water during a typical 12 min distillation run at 25 kW input power are shown in fig. 5. As expected, the heat loss to the torch cathode is very small (about 0.35 kW), but the loss to the anode (about 4.6 kW) is almost 20% of the total input power. In the present design of furnace, the anode of the plasma torch receives much radiant heat from the furnace hot zone, so that the anode heat loss figure is about 0.5 kW higher than that when the plasma torch operates alone (i.e. detached from the furnace). The quantity of heat lost to the furnace cooling water rises steadily during the experiment, as the alumina core heats up, and as its thickness diminishes by evaporation and fusion. At the twelfth minute of distillation, some 4.3 kW of heat is lost to the furnace cooling water, the core then being in places only about 1 cm thick. It is clear that a greater efficiency would be obtained if the furnace were to be fed continuously with fresh material. This, and the other improvements in the design of the torch and furnace should make it possible to approach more closely the theoretical power requirement for the process.

## 5. Products of Distillation

When the gases emerging from the furnace were

quenched with argon (130 l/min), and precautions were taken to handle the product out of contact with air, a fine grey powder, which contained 11.4% of metallic aluminium, was produced. The powder was pyrophoric in air. X-ray powder analysis showed that in addition to free metal there were also present  $\gamma$ - $\text{Al}_2\text{O}_3$  and the two oxycarbides  $\text{Al}_2\text{OC}$  and  $\text{Al}_4\text{O}_4\text{C}$ . There was no evidence of the presence of aluminium nitride despite the fact that nitrogen was the major constituent of the plasma gas.

These observations are in accordance with the expectation that the major aluminium-containing vapour species under our conditions are  $\text{Al}_2\text{O}$  and  $\text{Al}$ . The lower oxides of aluminium are unstable in the solid state, relative to alumina and free aluminium, and the latter may react with carbon monoxide to yield the two oxycarbides. It would appear that either the quench rate, or the rate of oxycarbide formation, was too high to permit significant reaction of metallic aluminium to form the nitride.

The reduced materials being difficult to handle, the hot vapour issuing from the furnace was generally oxidised and quenched with jets of air (typically at 200 l/min). Detailed examination of the fully oxidised product will be discussed elsewhere. However, certain conclusions are possible here.

The product consists of a voluminous white powder, shown by X-ray powder analysis to be predominantly  $\gamma$ - $\text{Al}_2\text{O}_3$  with smaller amounts of  $\delta$ - $\text{Al}_2\text{O}_3$ . An electron micrograph of a typical sample is shown in fig. 6. The particles are all spherical, as expected for a material which has

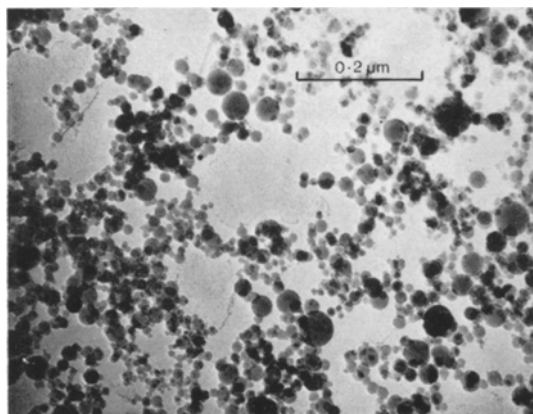

Figure 6 Electron micrograph of a typical sample of ultra-fine alumina product.

condensed as liquid droplets. There is a strong tendency for the particles to agglomerate as chains or more complex structures. This process is typical of other fine powders we have produced by this means, and probably occurs via random aggregation [14]. The ultimate particle size depends on experimental conditions, but the surface area of the sample shown in fig. 6 was  $79\text{ m}^2/\text{g}$  by the BET nitrogen adsorption method [15]. This corresponds to a mean particle size (calculated for spherical particles of density  $3.4\text{ g/cm}^3$ ) of about 22 nm.

Work is now in progress to study the effect of modifying the quench conditions. Surface areas  $> 130\text{ m}^2/\text{g}$  have been achieved (higher than those claimed for commercially available fumed aluminas) and higher surface areas should be possible. It would appear that fine alumina prepared by this technique could be commercially competitive with that prepared by alternative routes, and potential applications include reinforcement of elastomers, viscosity control of liquids, and also improving the flow of fine powders. In the field of ceramic fabrication, these materials have potential both as sintering aids, and in hot-pressing to produce dense alumina bodies. The availability of these metastable oxides with high surface areas suggests their use, either as catalysts, or as catalyst supports, and development into the field of co-condensed mixed oxides should further enhance the catalytic activity of powders produced by this technique.

## References

1. A. AUDSLEY and P. K. BAYLISS, *J. Appl. Chem.* **19** (1969) 33.
2. I. H. WARREN and H. SHIMIZU, *Can. Min. Metall. Bull.* **58** (1965) 551.
3. J. D. HOLMGREN, J. O. GIBSON, and C. SHEER, *J. Electrochem. Soc.* **111** (1964) 362.
4. S. KORMAN and C. SHEER, *Electrochem. Soc. Symposium, Philadelphia*, 1966.
5. A. V. GROSSE, P. J. MCGONIGAL, W. J. MURPHY, and C. S. STOKES, *Mater. Res. and Standards* **5** (1965) 173.
6. M. FOEX, D. YEROUCHALMI, and R. DELMAS, *Compt. Rend. Acad. Sci. (Paris)* **270(C)** (1970) 1082.
7. B. SELTON and J. A. SHEWARD, *J. Mater. Sci.* **4** (1969) 302.
8. J. DROWART, G. DEMARIA, R. P. BURNS, and M. G. INGRAM, *J. Chem. Phys.* **32** (1960) 1366.
9. L. BREWER and A. W. SEARCY, *J. Amer. Chem. Soc.* **73** (1951) 5308.
10. G. GITLESEN, O. HERSTAD, and K. MOTZFELDT, "Selected Topics in High Temperature Chemistry",

- ed. T. Førland, K. Grjotheim, K. Motzfeldt, and S. Urnes (Univeritetsforlaget, Oslo, 1966) p. 179.
11. JANAF Thermochemical Tables, Dow Chemical Co, Midland, Michigan, USA.
12. J. A. SHEWARD, National Physical Laboratory Report, IMS Ex. 1, 1966.
13. T. B. REED, "The Application of Plasmas to Chemical Processing", ed. R. F. Baddour and R. S. Timmins (Pergamon, 1967) p. 26.
14. D. N. SUTHERLAND, *Nature* **226** (1970) 1241.
15. S. BRUNAUER, P. H. EMMETT, and E. TELLER, *J. Amer. Chem. Soc.* **60** (1938) 309.

Received 29 December 1970 and accepted 13 January 1971.